



Accurately Weighing Africa



BELT SCALES

IN-MOTION PRECISION PERFECTED



BS-24-01

SMART SUPPORT
0861 422 134
OR +27 83 680 0722
E-mail: info@sascoafrica.com
Web: www.sascoafrica.com
24 hours, 7 Days a week

SASCO WEIGHING SYSTEMS

GROUP SUPPORT H/O
2 Blackburn Street
Apex Industrial | Benoni

Phone: +27 (0) 11 746 6000
Fax: +27 (0) 11 746 6100

SASCO BELT SCALES offer the most accurate and efficient way to measure material flow over a conveyor belt. The belt scale consists of the weighing mechanics, the scale bed, between one and four profiled weighing idlers, between two and six pre and post-scale profiled idlers, load cells, a tachometer and a weighing integrator transmitter. The integrator processes data received from the weighing idlers and tachometer. This results in both indicated and re-transmissible flow rate (T/hr) and totalizer (T).

The selection of the weighing frame, the number of weighing idlers and the number of pre and post-idlers determine the weighing system's accuracy. In contrast, the choice of the controller determines the functionality and connectivity of the belt weighing system.

Sasco Belt Scales

Sasco offers a broad range of rugged and accurate belt weighing systems, all of which can be tailor-made to meet customers' specific requirements, with three configurations being central to Sasco's product offering, namely the BS100, BS200 & BS300 Belt Scales.

Sasco Belt Scales provide solutions for nearly every application from inventory to load-out, blending & control. They are perfect for use in the food, recycling, chemicals, steel, timber, coal, sand, animal feeds and grain industries, amongst others.



TYPICAL IN-SITU BELT SCALE ON PRODUCT FEED APPLICATION.

Product Overview

SASCO BELT SCALES have the following key component options, which are reflected in our range of standard belt weighing product range and bespoke product options.

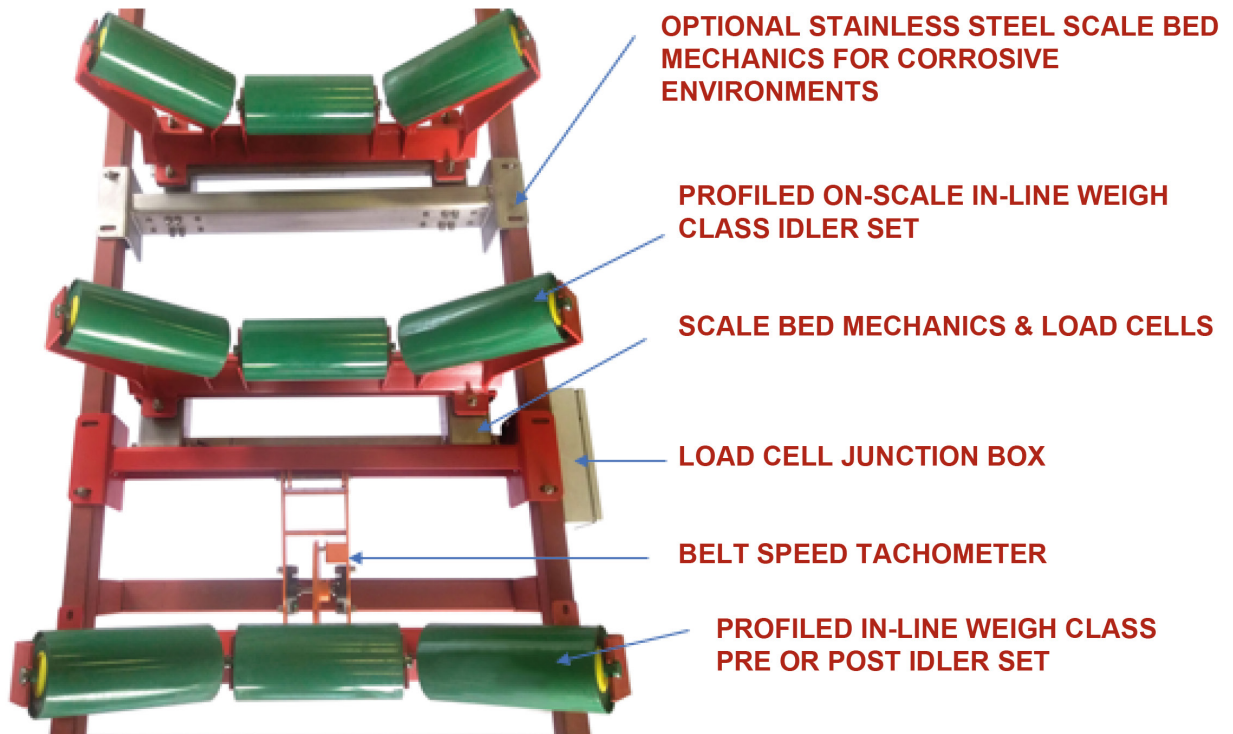

Belt Scale Mechanical Overview



Standard Product Range

DELIVERING ACCURATE IN-MOTION BULK WEIGHING

The Sasco Belt Scale range comprises both bespoke products and the following standard base products:

PRODUCT NUMBER	BS - 100	BS - 200	BS - 300
			
	BW100 Controller	BW100 Controller	BW100 Controller
Applications	Process Weighing or Flow Rate Indication	Plant Inventory	Product Accounting or Stock Pile Accounting
STANDARD FEATURES			
IP65	Yes	Yes	Yes
Totaliser Pulse O/P	Yes	Yes	Yes
Analog Feedrate O/P	Yes	Yes	Yes
Operator Keypad	Yes	Yes	Yes
SPECIFICATIONS			
Conveyor Width	450 - 1200MM	450 - 1500MM	600 - 2200MM
Capacity	> 15 TPH < 1 000 TPH	> 20 TPH < 5 000 TPH	> 20 TPH < 10 000 TPH
Belt Speed	0 - 2,0 M/S	0 - 4.0 M/S	0 - 6,0 M/S
Material	Wide Range	Wide Range	Wide Range
System Accuracy	< 2%	< 1%	< 0,5%
Weigh Idlers	1	2	4 - 6
Pre/Post Idlers	4	6	6
Warranty	12 months	12 months	12 months
OPTIONS			
Custom Paint	Yes	Yes	Yes
Stainless Steel	Yes	Yes	Yes

Controller Features Comparison

	
Display	6 digits LED + 128 x 64 LCD
Serial Ports	RS-232 or RS-485
USB Port	No
Ethernet Port	No
Hardware Slots	No
Operator Functions	Zero adjustment, reset totalizer, set points, date and time
Audit Trail	Yes
Controls and Alarms Set Points	Yes
I/O Digital Channels	3 In/Out
Ticket Formats	Print unit no, date, time and weighing information
Filter Settings	Yes



Sasco Belt Scale Installation in Ghana

Specification Requirements

The following details are critical for the correct specifications of a belt scale to be arrived at:

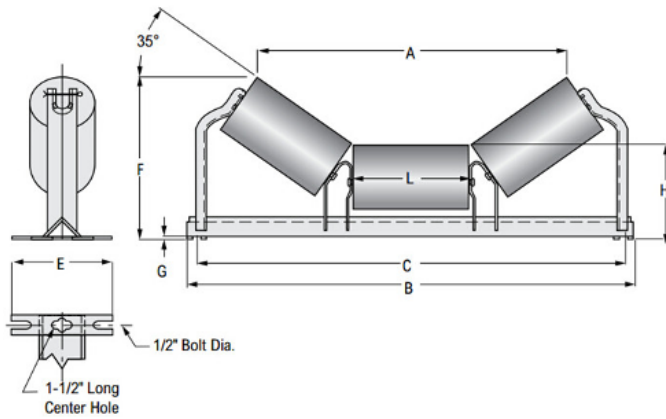

A	-	BELT WIDTH
B	-	STRINGER OUTSIDE DIMENSION
C	-	CENTRE TO CENTRE DIMENSION
E	-	MOUNTING BRACKET WIDTH
F	-	HEIGHT FROM TOP OF STRINGER TO TOP OF ROLLER
G	-	MOUNTING BRACKET THICKNESS
H	-	HEIGHT FROM TOP OF STRINGER TO TOP OF MIDDLE ROLLER
L	-	ROLLER LENGTH TROUGHING ANGLE

Conditions

Product Conveyed _____

Particle Size _____ mm

Bulk Density _____

Maximum Required Feed _____ T/h

Conveyor Belt Speed _____ m/sec

Scale Idler Pitch _____ mm

Conveyor Incline _____ °

Conveyor Total Length _____ m

Conveyor Take-up Gravity Screw Hydraulic None _____

Belt Thickness (Class & Ply) _____ mm

Accuracy Required _____ %

Instrumentation Spec

Totaliser Pulse output required Yes No _____

Serial Communication Required _____

Weigh feeder control Required Yes No _____

Supply Voltage available _____ VAC

Installation Required Yes No _____

Application Example

BELT SCALE

Coal washing **Plant A** washes up to 120 000 tons of raw coal per month (ROM). The washing plant is currently utilising a manual surveying system. This process is problematic due to the element of human error.

The plant needs a solution for the problems of:

- Accounting for the quantity of raw coal being fed into the plant via the primary crusher.
- Accounting for the difference between the raw coal being fed into the plant and discard material being manually removed at the secondary crushing point.
- Accounting for the discrepancy between raw crushed and screened coal moving into the wash plant and processed coal moving out of the wash plant.
- Providing an overall plant balance and thereby confirming the plant yield providing metrological personnel with a reliable indication of the plant efficiency.
- Providing surveying personnel with a second reliable confirmation of material stock-piles after the manual survey process.

Our custom-engineered BS-300 belt scale will provide an optimal and rugged solution. Our BW 100 weighing controller which offer all industry standard and many other optional features, provide state-of-the-art, technically advanced weighing excellence.

The two combined will offer a repeatable, accurate and reliable source of weighing information.

A six belt scale solution will be configured as follows:

- No. 1 conveyor, the primary crushing conveyor, will have a belt scale in order to measure crushed R.O.M. raw material moving into the plant.
- The larger pieces of discard material will still be manually removed at the screen plant just after no. 1 conveyor.
- Screened and crushed material will run through a secondary crusher and from there onto a stockpile.

- Material will then move from the stockpile onto no. 2 plant feed conveyor via the secondary crusher and then run over a belt scale. This belt scale will weigh the crushed and screened material as it moves into the wash plant, serving the following purposes:
 - » Determining the quantity of discarded material.
 - » Determining the quantity of crushed, screened material moving into the washing plant.
 - » Determining the exact instantaneous material flow rate into the wash plant and thus allowing the operator to set the wash plant feed rate to optimal efficiency.
-
- Once in the wash plant material will be initially graded by size and from there will be washed in order to separate the discard material from the saleable materials.
- These materials will then be transported via conveyors to four holding hoppers for the finer discard material and three different grades of coal.
- Each of the four holding hoppers' feed conveyors will incorporate a belt scale in order that material moving out of the wash plant can be accounted for.
- Data on the weighing process is available on each individual belt scale integrator with optional communications and retransmission of information in various formats being readily available.



SMART SUPPORT
 0861 422 134
 OR +27 83 680 0722

E-mail: info@sascoafrica.com
 Web: www.sascoafrica.com
 24 hours, 7 Days a week

This brochure contains a general guide of the product only and shall not form part of any contract unless specifically agreed by Sasco Africa in writing in each case on the Order Acknowledgement. The specification of the product described herein may vary from time to time and may be altered without notice.

LOCAL SUPPORT AGENT

